





**ELECTRONIC MULTI-FUNCTION
THREE-PHASE DIRECT CONNECTION METER**

MTF301

USER MANUAL

MTF301-1-02563-51011-31010

WARNINGS / SYMBOLS

<p>DANGER</p> 	<p>Death, serious injury, or fire hazard could result from improper connection of this instrument. Read and understand this manual before connecting this instrument. Follow all installation and operating instructions while using this instrument.</p> <p>Installation, operation, and maintenance of this instrument must be performed by qualified personnel only. The National Electrical Code defines a qualified person as “one who has the skills and knowledge related to the construction and operation of the electrical equipment and installations, and who has received safety training on the hazards involved.”</p>
<p>WARNING</p> 	<p>Consult the instruction manual before using the equipment.</p> <p>In this manual, if the instructions preceded by this symbol are not met or done correctly, can cause personal injury or equipment damage and / or facilities.</p>

1. GENERAL DESCRIPTION OF THE METER	5
1.1 INTRODUCTION	5
1.2 METROLOGY	6
1.3 PARAMETERS MEASURED	6
1.4 NOMINAL, MAXIMUM AND MINIMUM OPERATING CONDITIONS.....	6
1.4.1 <i>Electrical parameters</i>	6
1.4.2 <i>Environmental parameters</i>	7
1.5 BUILD FEATURES.....	7
1.5.1 <i>General information</i>	7
1.5.2 <i>Environmental characteristics</i>	7
1.5.3 <i>Voltage connection</i>	7
1.5.4 <i>Seals</i>	7
1.5.5 <i>Terminal cover</i>	8
1.5.6 <i>Terminal block</i>	8
1.6 DISPLAY OF DATA.....	9
1.7 VERIFICATION IMPULSES.....	10
1.8 PUSH-BUTTON	10
1.9 NAMEPLATE	10
1.10 CONNECTIONS.....	11
1.11 REAL-TIME CLOCK.....	11
1.12 BATTERY AND RESERVE POWER.....	12
1.13 OPTICAL COMMUNICATIONS PORT	12
1.14 ELECTRICAL RS485 COMMUNICATIONS PORT	12
1.15 ACCESSORIES	12
1.15.1 <i>Season</i>	12
1.15.2 <i>Classification of days</i>	13
1.15.3 <i>Tariff period</i>	13
1.16 MAXIMETER	13
1.17 LOAD PROFILE	13
1.18 EVENTS.....	14
1.19 DAYLIGHT SAVING TIME	14
1.20 TECHNICAL SPECIFICATIONS	14
1.21 SAFETY	17
1.21.1 <i>Tamper detection</i>	17
1.21.2 <i>Protection of the information saved in the memory</i>	17
1.21.3 <i>Seals</i>	18
2. APPLICABLE STANDARDS	18
3. METER CALCULATIONS.....	19
3.1 NOMINAL VOLTAGE	19
3.2 NOMINAL CURRENT.....	19
3.3 APPARENT POWER.....	19
3.4 ACTIVE POWER.....	19
3.5 REACTIVE POWER.....	19
3.6 POWER FACTOR	19
3.7 MAXIMUM DEMAND	19
3.8 ENERGY	20
4. OPERATION OF THE METER	20
4.1 BROWSING AND DISPLAY MODES.....	20

4.1.1	<i>Auto-rotate Mode</i>	20
4.1.2	<i>Manual Mode (Power On)</i>	20
4.1.3	<i>Manual Mode (Power Off)</i>	21
4.1.4	<i>Special Mode</i>	21
5.	OBIS CODES	22
6.	INSTALLATION AND START UP	30
6.1	INSTALLING THE EQUIPMENT	30
6.2	METER CONNECTION LAYOUT	30
7.	TECHNICAL SERVICE	30

1. GENERAL DESCRIPTION OF THE METER

1.1 Introduction

MTF301 is a three-phase static meter for metering purposes. Class 1 for active energy (IEC 62052-11 and IEC 62053-21) and Class 2 for reactive energy (IEC 62053-23) with optical and RS485 communications in compliance with IEC 62056-21 standard.



1.2 Metrology

The metrological characteristics of the MTF301 three-phase direct connection meter are:

- Current transformer (CT) type current sensor
- Active accuracy class = 1 for $I > 20$ mA with $\cos \varphi = 1$
- Reactive accuracy class = 2 for $I > 25$ mA with $\sin \varphi = 1$
- Start-up current (I_{st}) = 20 mA for $\cos \varphi = 1$ at the nominal voltage
- Base or reference nominal current (I_b/I_n) = 5 A
- Maximum current (I_{max}) = 100 A
- Minimum current (I_{min}) = 20 mA

1.3 Parameters measured

The meter can measure the following parameters:

- Imported and exported active energy (kWh) and reactive energy (kVArh) in four quadrants
- Active power (kW), reactive power (kVAr), and apparent power (kVA)
- Instantaneous current (A) and voltage (V)
- Line frequency (Hz)
- Power factor ($\cos \varphi$)

1.4 Nominal, maximum and minimum operating conditions

1.4.1 *Electrical parameters*

- Reference voltage (U_{ref}): 3x230/400 V
- Operating voltage range
 - minimum: 80% U_{ref}
 - maximum: 115% U_{ref}
- Operating limit voltage: 500 V
- Reference frequency: 50 Hz
- Power consumption per phase: <2 W; <10 VA for I_b , U_{ref}

1.4.2 Environmental parameters

- Operating temperature range
 - minimum: -40 °C
 - maximum: +70 °C; 95 % relative humidity
- Storage temperature range
 - minimum: -40 °C
 - maximum: +80 °C; 98 % relative humidity

1.5 Build features

1.5.1 General information

The meter has an insulating enclosure with protection class "Class II" with double insulation.

The materials used have the following features: fire retardant, halogen free and with low emissions of opaque, toxic or corrosive fumes. The unit's operation will not be affected by the presence of external magnetic fields.

The meter manufacturer certifies that the meter has a service life of 20 years, running at a temperature of 23 °C.

1.5.2 Environmental characteristics

The meter provides following features:

- IP54 Code degree of protection provided by the enclosure elements, IEC 62052-11 part 5.9
- Resistant to ultraviolet rays, IEC 62052-11 part 6.3.4

1.5.3 Voltage connection

The jumper on the sealed terminal block separates the voltage and current circuits, making it impossible to manipulate them externally.

1.5.4 Seals

The cover and base of the meter are sealed in a way that prevents unauthorized access, theft or tamper (IEC 62052-11 part 5.5). Any attempt of opening the meter's main cover is not

possible unless by breaking the meter's case. In addition, the meter is equipped with a regulatory seal on the terminal and wire cover.

The meter has an expansion module to add external battery and to activate the program button. The cover of this module is equipped with a manufactory seal to prevent unauthorized access to the external battery slot and the program button.

1.5.5 Terminal cover

The meter has a transparent cover that covers the top section of the terminal block, with fixing screws and connection conductors.

The bottom part is designed in such a way that it can be easily broken to allow the wires to be partially exposed while protecting access to the terminals.

The meter is equipped with a sensor that can detect the opening and closing of the terminal cover. This detection always takes place, even if the meter is not connected to the electrical supply.

1.5.6 Terminal block

All terminals are numbered on the front, from left to right, with the function of the meter being indicated on the characteristics label situated on the meter's casing, indicating the conductor's function, in accordance with the DIN standard:

- 1 → Phase 1 conductor input
- 3 → Phase 1 conductor output to user
- 4 → Phase 2 conductor input
- 6 → Phase 2 conductor output to user
- 7 → Phase 3 conductor input
- 9 → Phase 3 conductor output to user
- 10 → Neutral conductor input and output to user

The auxiliary terminals for electrical communication interface RS485 are located a level above the main terminals, and they are numbered from left to right, starting at 13.

1.6 Display of data

Data is displayed on an LCD screen, which has been specially designed for this application. All of relevant information can be viewed on the display, including: energy values, electrical parameters, status indicators, etc.

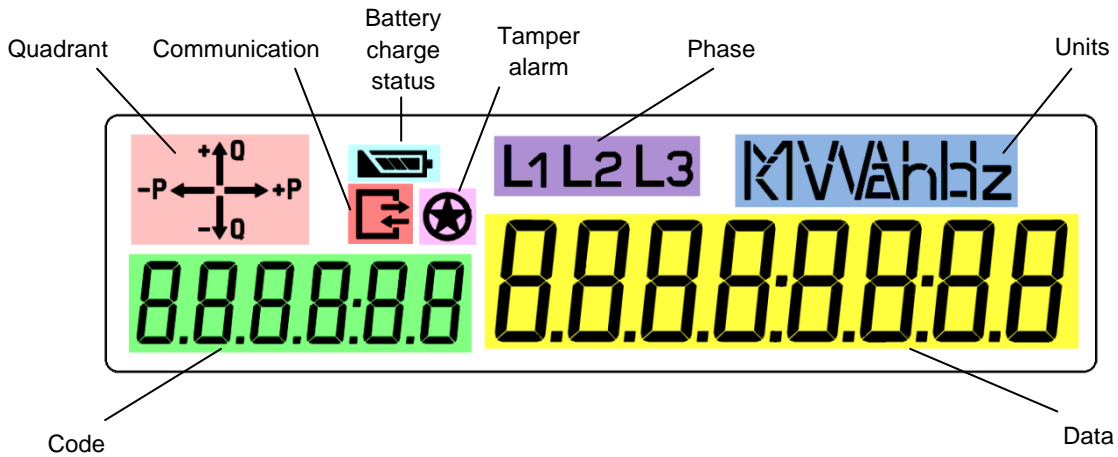

- *Code:* shows the OBIS code for the variable being displayed in the data section
- *Data:* area where information about the electrical parameters, energy etc. is displayed
- *Units:* unit of the parameter that is being displayed (kWh, kW, kvarh, V, A, h, etc.)
- *Indicators:* the meter uses the first line of LCD to show the following indicators:

	Indicates the current working quadrant and energy flow
	Indicates the battery charge status. When the battery is in low voltage, an alarm will be triggered on the LCD showing the date of necessary battery replacement
	If the meter is in the process of communication, this symbol is shown
	Indicates the tampering of meter. Use <i>read</i> button to access the log file. Use <i>reset</i> button to clear the alarm sign.
L1 L2 L3	Indicates the presence of electrical current in each phase

1.7 Verification impulses

The meter has two verification LED with a constant of

- 400 imp / kWh for active energy (first verification LED from left to right)
- 400 imp / kvarh for reactive energy (second verification LED from left to right)

These LED will be used for

- Signaling the "no load" state. The LED will start to blink as soon as the meter's load is enough to start it
- Verification of active and reactive energy measurement



1.8 Push-button

The meter has two push-buttons which are activated by pressing or holding them down. The keys can be pressed down during less than 3 seconds, or held down during more than 3 seconds. This depends on the display mode that shall be selected by the user.

1.9 Nameplate

The nameplate is on the meter's front panel and includes specific indications, in compliance with IEC 62052-11:

- Manufacturer's identification mark and place of manufacture
- Description of the type and indications related to the approval of the meter
- Number of phases and number of conductors of the circuit it can be connected to (for example: three-phase 4 wire)
- Serial number of the meter (8 numerical characters)
- Year of manufacture
- Reference voltage, in the form of the voltage assigned to the network
- Reference and maximum current, for example 5(100) is a meter with a base current of 5A and a maximum current of 100A
- Reference frequency in Hz
- The meter's constant for active and reactive energy pulse ration; it defines the LED flashing frequency which is described as 400 impulses per kWh and 400 impulses per kvarh
- The accuracy class index of the meter

- Double square symbol  , showing that it is a meter with a protection class II isolating enclosure
- Description of the number and arrangement of measurement elements
- Meter identification barcode
- Manufacturer code to identify the meter model. This code is used to describe the setup, power supply, current measurement, measurement system, etc.
- IP code degree of protection provided by the enclosure elements
- General danger information symbol  , warning about the risk of injury from current carrying parts and never to operate the meter without its terminal cover

1.10 Connections

The diagram of electrical connections of the meter is engraved in the lower part of the terminal cover. This is to facilitate the start-up tasks.

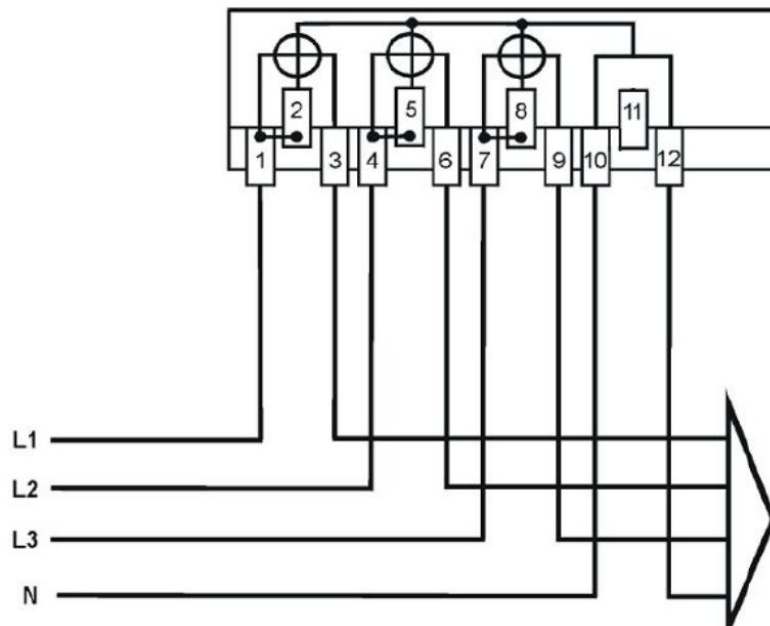

1.11 Real-time clock

The meter also has a built-in real-time clock that will display the date and hour with a maximum error of ± 0.5 seconds per day at 23°C , as specified in the IEC 62054-21 standard.

The clock will maintain its accuracy degree when powered by the electrical network or its own battery.

1.12 Battery and reserve power

The meter is equipped with a supercap and internal lithium battery to keep the clock operating in real-time. This battery is non-removable and is designed with a life cycle of 20 years. It keeps the meter's real-time clock running during 2 years when the meter is without power.

Furthermore, the meter has the capability to add an external lithium battery to power the meter in case the internal lithium battery has reached the end of its life cycle. For this purpose, there is an empty space in the right part of the external battery cover on the meter case where the external battery can be inserted. The replacement of external battery is easy and there is no need to solder and access the meter's internal circuits. Additionally, the external battery cover can be sealed in the meter case.

1.13 Optical communications port

The meter has a series optical communications port D0, in compliance with IEC 62056-21 standard. The communications port is fully compatible with the optical probes certified by the main utilities and power distribution companies.

On the meter cover there is a ring for the correct fixing and location of optical probes.

1.14 Electrical RS485 communications port

The meter has a series electrical communications port RS485, in compliance with IEC 62056-21 standard. The communications port is designed as a 2 wire connection with the same protocol as the optical communications port.

The recommended arrangement of the wires is as a connected series of point-to-point nodes, a line or bus, not a star, ring, or multiply-connected network. The wires are connected to the meter using the auxiliary terminals number 25 and 26.

1.15 Accessories

1.15.1 Season

The season defines each period of time in which a natural year is divided and during which the associated tariff structure does not vary. There are a maximum of 4 seasons.

The seasons are pre-defined by the official calendar in Iran (Shamsi calendar) along with official hour change dates, with no need to establish additional parameters and are adjusted automatically each year.

1.15.2 Classification of days

Days can be classified as follows:

- Working days
- Holidays

Working days include Saturdays, Sundays, Mondays, Tuesdays, Wednesdays, Thursdays and Fridays. All have the same tariff treatment throughout a season.

Holidays are other national or religious holidays included in the calendar as such. All have the same tariff treatment throughout a season. Holidays will be identified with their date. There will be a maximum of 30 holidays which can be defined for the meter.

1.15.3 Tariff period

A tariff period is defined as each hourly block in which a determined tariff is applied. The power distribution company defines such periods for the regional market. There will be a minimum of one hourly block and a maximum of six.

1.16 Maximeter

The maximum demand is defined as the mean value of active power requested within any defined period minutes, in a time considered between two consecutive billing closure periods.

The measurement periods will start at the time when the meter is powered on, ending at the start of the next period.

The maximum demand will be associated to each tariff period defined and to the whole set. Each of these values has the date, hour and minute of the event identified.

The 15 minute periods in which there has been a synchronism, cut-off or reinstatement of the power supply, or with an invalidation bit, change of parameters or tampering events, will not be taken into account to calculate maximum values.

1.17 Load profile

The recording unit has a load profile that complies with the specifications of German VDEW regulations. The load profile has four channels and stores the records with the following parameters:

1. Total Import Active Energy |A|
2. Total Import Active Power |P|

3. Voltage U
4. Current I

The maximum number of records stored is 4,000 and the integration period can be fully configured by the user.

In the event of voltage drops or in the case of daylight savings time, the gaps in the load profile will be completed with invalid zero values. An incremental value of the load profile that does not fully correspond to the hour in which it is included will be marked as invalid. For example, in the case of a value that corresponds to the consumption of various hours.

1.18 Events

All of the dates of setup modifications, power outages, terminal cover removals, power excesses, etc. are registered.

The device has a storage capacity of 200 registers. Data within the file is organized in a round-robin structure. This means that once the memory is full, the new data will be saved over the top of the oldest data. This system ensures that the meter always has up-to-date information, and that this corresponds to the latest obtained data.

1.19 Daylight saving time

The recording system of the meter will automatically make the changes necessary for daylight saving time. The official hour change parameters are according Iranian law:

- The time is set forward (+1 hour) the next second after 23:59:59 on the 01.01. of each year
- The time is set backward (-1 hour) the next second after 23:59:59 on the 30.06. of each year

1.20 Technical specifications

Power Supply

Mode	Self-powered
Nominal voltage	3 x 230 / 400 V
Tolerance	+15% / -20%
Consumption	< 2 W 10 VA
Frequency	50 Hz
Operating temperature	-40°C to +70°C

Voltage measurement

Connection	Asymmetrical (DIN standard)
Reference voltage	3 x 230 / 400 V
Frequency	50 Hz
Self-consumption of the voltage circuit	0.74 W , 0.9 VA

Current measurement

Currents (I_n)	5 A Direct (max. 100 A)
Maximum current	100 A
Start-up current	20 mA
Self-consumption of the current circuit	0.05 VA

Accuracy

Active energy	Class 1
Reactive energy	Class 2

Calculation and processing

Microprocessor	RISC 16 bits
Converter	19 bits

Memory

Data	RAM type, stored by Lithium battery
Setup, events, load profile	1024 kBit, non-volatile memory, EEPROM type

Battery

On-board	Lithium, ER14250 type
External	Lithium Coin, CR2032 or LIR2032 type
Working life	20 years

Clock

Source	Self-compensated quartz crystal oscillator
Drift	< 0.5 s / day at 23 °C and 0.15 s / day for each additional 1 °C

Communication interfaces

Optical port D0	according to IEC 62056-21, 4800 baud rate, mode C
Electrical port RS485	according to IEC 62056-21, 4800 baud rate, mode C

Tamper detection

Activation	Manipulation of the meter or connections
Delay	Activation is delayed 15 minutes to facilitate the installation

Tests / Standards

IEC 62052-11 clause 7.3.2	Impulse voltage
---------------------------	-----------------

Tests / Standards

IEC 62053-21 clause 7.4	AC voltage
IEC 62053-21 clause 8.4	Meter constant
IEC 62053-21 clause 8.3.3	Starting conditions
IEC 62053-21 clause 8.3.2	No-load condition
IEC 62053-21 clause 8.2	Temperature
IEC 62053-21 clause 8.2	Voltage
IEC 62053-21 clause 8.2	Frequency
IEC 62053-21 clause 8.2.1	Harmonics in circuit current and voltage
IEC 62053-21 clause 8.2.2	Influence of odd harmonics on AC currents
IEC 62053-21 clause 8.2.3	Influence of direct current and even harmonics on AC currents
IEC 62053-21 clause 8.2.4	Influence of continuous magnetic induction of external origin
IEC 62053-21 clause 8.2	Influence of magnetic induction of external origin
IEC 62053-21 clause 8.2	Operation of accessories during communication with ports
IEC 62053-21 clause 8.1	Limits of error due to variation of the current
IEC 62053-21 clause 8.3.1	Initial start-up of the meter
IEC 62053-21 clause 7.1	Power consumption in the voltage and current circuit
IEC 62053-21 clause 7.1.2	Influence of supply voltage
IEC 62053-21 clause 7.2	Influence of short-time over-current
IEC 62053-21 clause 7.3	Influence of self-heating
IEC 62053-21 clause 7.2	Influence of temperature
IEC 62053-21 clause 7.2	Immunity against earth error
IEC 62052-11 clause 7.5.8	Radio interference suppression
IEC 62052-11 clause 7.5.4	Fast transient burst
IEC 62052-11 clause 7.5.5	Radio-frequency electromagnetic fields (RF)
IEC 62052-11 clause 7.5.2	Immunity to electrostatic discharges
IEC 62052-11 clause 7.5.6	Surge immunity
IEC 62052-11 clause 6.3.1	Dry heat
IEC 62052-11 clause 6.3.2	Cold
IEC 62052-11 clause 6.3.3	Cyclic damp heat
IEC 62052-11 clause 5.2.2.3	Vibration
IEC 62052-11 clause 5.2.2.2	Shock
IEC 62052-11 clause 5.2.2.1	Spring hammer
IEC 62052-11 clause 5.9	Protection against penetration of dust and water

Tests / Standards

IEC 62052-11 clause 5.8	Resistance to heat and fire
IEC 62052-11 clause 5.3	LCD screen and sealing
IEC 62052-11 clause 5.4	Terminals
IEC 62052-11 clause 5.4	Mechanical strength of terminals
IEC 62052-11 clause 5.5	Terminal cover inspection
IEC 62052-11 clause 5.6	Creepage and clearance distances of the terminals
IEC 62052-11 clause 5.11	Output pulse
IEC 62052-11 clause 5.12	Marking of meter
IEC 62052-11 clause 5.10	Display of measured values

1.21 Safety

1.21.1 Tamper detection

The meter will generate an event and activate the alarm whenever its terminal cover is lifted. The alarm will only be deactivated when the terminal cover is placed back. To remove the alarm symbol from the LCD screen, a password protected software command must be sent.

1.21.2 Protection of the information saved in the memory

All accesses via the communications system to the meter's memory are protected with 3 read and write codes.

For each code, a specific access level is defined to prevent low-level users from accessing confidential high-level information.

These codes have more than 100 million combinations, so that the meter will be heavily protected against the alteration of recorded information (load curves, events, billing, setup).

To further increase safety of information, the meter's security mechanism uses a time lock for each unauthorized access as follows:

- First access with incorrect password: the display flashes and all communication ports are locked for 3 seconds
- Second access with incorrect password: the display flashes and all communication ports are locked for 5 seconds

- Third access with incorrect password: the display flashes and all communication ports are locked for 60 seconds
- Fourth access with incorrect password: the display flashes and all communication ports are locked for 24 hours

1.21.3 Seals

The meter case is sealed by design in order to prevent access to the electronics. Any attempt to open the meter by force will cause the breaking of the meter cover.

The meter can be further protected by using a terminal cover seal and external battery cover seal.

2. APPLICABLE STANDARDS

The MTF200F meter complies with the following standards:

- *IEC 62052-11:2003* - Electricity metering equipment (AC) - General requirements, tests and test conditions - Part 11: Metering equipment
- *IEC 62053-21:2003* - Electricity metering equipment (AC) - Particular requirements - Part 21: Static meters for active energy (classes 1 and 2)
- *IEC 62053-23:2003* - Electricity metering equipment (AC) - Particular requirements - Part 23: Static meters for reactive energy (classes 2 and 3)
- *IEC 62056-21:2002* - Electricity metering equipment (AC) - Particular requirements - Part 23: Static meters for reactive energy (classes 2 and 3)

3. METER CALCULATIONS

3.1 Nominal Voltage

$$V_{RMS} = \sqrt{\frac{1}{64} \sum_{n=1}^{64} v_n^2}$$

3.2 Nominal Current

$$I_{RMS} = \frac{S}{V_{RMS}}$$

3.3 Apparent Power

$$S = \sqrt{P^2 + Q^2}$$

3.4 Active Power

$$P = \frac{1}{64} \sum_{n=1}^{64} v_n i_n$$

3.5 Reactive Power

$$Q = \frac{1}{64} \sum_{n=1}^{64} v_n i_{n90}$$

3.6 Power Factor

$$FP = \frac{P}{S}$$

3.7 Maximum Demand

The maximum demand is calculated from the instantaneous power of each second. This power is averaged over a period of integration (15 minutes), obtaining MD_{15} .

$$MD_{15} = \frac{1}{900} \sum_{n=1}^{n=900} P_n$$

The maximum demand between two billing periods corresponds to maximum of each of these values averaged every 15 minutes (MD_{15}).

$$MAXDEM = Max(MD_{15})$$

3.8 Energy

$$ActiveEnergy = \sum_{n=1}^{n=\alpha} \frac{P_n}{3600}$$

$$ReactiveEnergy = \sum_{n=1}^{n=\alpha} \frac{Q_n}{3600}$$

4. OPERATION OF THE METER

This section describes the operation of the meter from the functional point of view, for example, we shall explain how the information provided must be managed and the different system functions must be configured.

4.1 Browsing and display modes

Use the push-button to browse the different information screens. Simply press the button to browse the screens of the same display mode. To access the special display mode, hold down the button. The system will return to the previous display mode if there is no activity after 10 seconds.

4.1.1 Auto-rotate Mode

The meter is in this mode by default when there is no activity on the push-buttons.

The purpose of the auto-rotate mode screens is to display the information in cycles, with no need to perform an action with the meter. The type of browsing is exclusive of the auto-rotate mode and the special mode (see 3.1.4). The LCD screen will alternate the information every 5 seconds.

4.1.2 Manual Mode (Power On)

This mode is activated by pressing the button when the meter is connected to power line.

The purpose of the manual mode screens is to display the information one by one by pressing the button. The system will return to auto-rotate mode if there is no activity after 10 seconds.

4.1.3 Manual Mode (Power Off)

This mode is activated by pressing the button when the meter is disconnected from power line.

The purpose of the manual mode screens is to display the information one by one by pressing the button. The LCD screen will automatically turn off if there is no activity after 5 seconds.

4.1.4 Special Mode

This mode is activated by holding down the button for 10 seconds when the meter is connected to power line.

The purpose of the special mode is to display information that goes beyond the default information, such as event log data. This mode displays the information in cycles, with no need to perform an action with the meter. The LCD screen will alternate the information every 5 seconds and will automatically return to auto-rotate mode after display of the last parameter.

5. OBIS CODES

Access to information that is registered by MTF301 meters is defined by either one of the four abovementioned display modes (see 3.1), or by communication according to IEC 62065-21 based on following OBIS codes.

OBIS	
00.09.01	Time
00.09.02	Date
<hr/>	
00.00.00	Serial Number
00.00.01	Device ID
00.00.02	Subscription ID
<hr/>	
14.07.00	Instant frequency
31.07.00	Instant current Line 1
51.07.00	Instant current Line 2
71.07.00	Instant current Line 3
91.07.00	Instant current Neutral
31.02.00	Maximum current Line 1
31.02.00.nn	Maximum current Line 1, Historical values (nn= 00 ... 15)
51.02.00	Maximum current Line 2
51.02.00.nn	Maximum current Line 2, Historical values (nn= 00 ... 15)
71.02.00	Maximum current Line 3
71.02.00.nn	Maximum current Line 3, Historical values (nn= 00 ... 15)
00.06.00	Instant voltage (Nominal)
32.07.00	Instant voltage Line 1
52.07.00	Instant voltage Line 2
72.07.00	Instant voltage Line 3
13.07.00	Instant power factor (Total)
33.07.00	Instant power factor Line 1
53.07.00	Instant power factor Line 2
73.07.00	Instant power factor Line 3
16.07.00	Instant active power (Total)
36.07.00	Instant active power Line 1
56.07.00	Instant active power Line 2

OBIS

76.07.00	Instant active power Line 3
131.07.00	Instant reactive power (Total)
151.07.00	Instant reactive power Line 1
171.07.00	Instant reactive power Line 2
191.07.00	Instant reactive power Line 3
09.07.00	Instant apparent power (Total)
29.07.00	Instant apparent power Line 1
49.07.00	Instant apparent power Line 2
69.07.00	Instant apparent power Line 3
<hr/>	
01.06.00	Maximum demand +A (Total)
01.06.00.nn	Maximum demand +A (Total), Historical values (nn = 00 ... 15)
01.06.01	Maximum demand +A, T1
01.06.01.nn	Maximum demand +A, T1, Historical values (nn = 00 ... 15)
01.06.02	Maximum demand +A, T2
01.06.02.nn	Maximum demand +A, T2, Historical values (nn = 00 ... 15)
01.06.03	Maximum demand +A, T3
01.06.03.nn	Maximum demand +A, T3, Historical values (nn = 00 ... 15)
01.06.04	Maximum demand +A, T4
01.06.04.nn	Maximum demand +A, T4, Historical values (nn = 00 ... 15)
02.06.00	Maximum demand -A (Total)
02.06.00.nn	Maximum demand -A (Total), Historical values (nn = 00 ... 15)
02.06.01	Maximum demand -A, T1
02.06.01.nn	Maximum demand -A, T1, Historical values (nn = 00 ... 15)
02.06.02	Maximum demand -A, T2
02.06.02.nn	Maximum demand -A, T2, Historical values (nn = 00 ... 15)
02.06.03	Maximum demand -A, T3
02.06.03.nn	Maximum demand -A, T3, Historical values (nn = 00 ... 15)
02.06.04	Maximum demand -A, T4
02.06.04.nn	Maximum demand -A, T4, Historical values (nn = 00 ... 15)
03.06.00	Maximum demand +R (Total)
03.06.00.nn	Maximum demand +R (Total), Historical values (nn = 00 ... 15)
03.06.01	Maximum demand +R, T1
03.06.01.nn	Maximum demand +R, T1, Historical values (nn = 00 ... 15)

OBIS

03.06.02	Maximum demand +R, T2
03.06.02.nn	Maximum demand +R, T2, Historical values (nn = 00 ... 15)
03.06.03	Maximum demand +R, T3
03.06.03.nn	Maximum demand +R, T3, Historical values (nn = 00 ... 15)
03.06.04	Maximum demand +R, T4
03.06.04.nn	Maximum demand +R, T4, Historical values (nn = 00 ... 15)
04.06.00	Maximum demand -R (Total)
04.06.00.nn	Maximum demand -R (Total), Historical values (nn = 00 ... 15)
04.06.01	Maximum demand -R, T1
04.06.01.nn	Maximum demand -R, T1, Historical values (nn = 00 ... 15)
04.06.02	Maximum demand -R, T2
04.06.02.nn	Maximum demand -R, T2, Historical values (nn = 00 ... 15)
04.06.03	Maximum demand -R, T3
04.06.03.nn	Maximum demand -R, T3, Historical values (nn = 00 ... 15)
04.06.04	Maximum demand -R, T4
04.06.04.nn	Maximum demand -R, T4, Historical values (nn = 00 ... 15)
05.06.00	Maximum demand R Q1 (Total)
05.06.00.nn	Maximum demand R Q1 (Total), Historical values (nn = 00 ... 15)
05.06.01	Maximum demand R Q1, T1
05.06.01.nn	Maximum demand R Q1, T1, Historical values (nn = 00 ... 15)
05.06.02	Maximum demand R Q1, T2
05.06.02.nn	Maximum demand R Q1, T2, Historical values (nn = 00 ... 15)
05.06.03	Maximum demand R Q1, T3
05.06.03.nn	Maximum demand R Q1, T3, Historical values (nn = 00 ... 15)
05.06.04	Maximum demand R Q1, T4
05.06.04.nn	Maximum demand R Q1, T4, Historical values (nn = 00 ... 15)
06.06.00	Maximum demand R Q2 (Total)
06.06.00.nn	Maximum demand R Q2 (Total), Historical values (nn = 00 ... 15)
06.06.01	Maximum demand R Q2, T1
06.06.01.nn	Maximum demand R Q2, T1, Historical values (nn = 00 ... 15)
06.06.02	Maximum demand R Q2, T2
06.06.02.nn	Maximum demand R Q2, T2, Historical values (nn = 00 ... 15)
06.06.03	Maximum demand R Q2, T3

OBIS

06.06.03.nn	Maximum demand R Q2, T3, Historical values (nn = 00 ... 15)
06.06.04	Maximum demand R Q2, T4
06.06.04.nn	Maximum demand R Q2, T4, Historical values (nn = 00 ... 15)
07.06.00	Maximum demand R Q3 (Total)
07.06.00.nn	Maximum demand R Q3 (Total), Historical values (nn = 00 ... 15)
07.06.01	Maximum demand R Q3, T1
07.06.01.nn	Maximum demand R Q3, T1, Historical values (nn = 00 ... 15)
07.06.02	Maximum demand R Q3, T2
07.06.02.nn	Maximum demand R Q3, T2, Historical values (nn = 00 ... 15)
07.06.03	Maximum demand R Q3, T3
07.06.03.nn	Maximum demand R Q3, T3, Historical values (nn = 00 ... 15)
07.06.04	Maximum demand R Q3, T4
07.06.04.nn	Maximum demand R Q3, T4, Historical values (nn = 00 ... 15)
08.06.00	Maximum demand R Q4 (Total)
08.06.00.nn	Maximum demand R Q4 (Total), Historical values (nn = 00 ... 15)
08.06.01	Maximum demand R Q4, T1
08.06.01.nn	Maximum demand R Q4, T1, Historical values (nn = 00 ... 15)
08.06.02	Maximum demand R Q4, T2
08.06.02.nn	Maximum demand R Q4, T2, Historical values (nn = 00 ... 15)
08.06.03	Maximum demand R Q4, T3
08.06.03.nn	Maximum demand R Q4, T3, Historical values (nn = 00 ... 15)
08.06.04	Maximum demand R Q4, T4
08.06.04.nn	Maximum demand R Q4, T4, Historical values (nn = 00 ... 15)
<hr/>	
01.08.00	Total active energy A
01.08.00.nn	Total active energy A , Historical values (nn = 00 ... 15)
01.08.01	Total active energy A , T1
01.08.01.nn	Total active energy A , T1, Historical values (nn = 00 ... 15)
01.08.02	Total active energy A , T2
01.08.02.nn	Total active energy A , T2, Historical values (nn = 00 ... 15)
01.08.03	Total active energy A , T3
01.08.03.nn	Total active energy A , T3, Historical values (nn = 00 ... 15)
01.08.04	Total active energy A , T4
01.08.04.nn	Total active energy A , T4, Historical values (nn = 00 ... 15)

OBIS

02.08.00	Export active energy -A
02.08.00.nn	Export active energy -A , Historical values (nn = 00 ... 15)
02.08.01	Export active energy -A , T1
02.08.01.nn	Export active energy -A , T1, Historical values (nn = 00 ... 15)
02.08.02	Export active energy -A , T2
02.08.02.nn	Export active energy -A , T2, Historical values (nn = 00 ... 15)
02.08.03	Export active energy -A , T3
02.08.03.nn	Export active energy -A , T3, Historical values (nn = 00 ... 15)
02.08.04	Export active energy -A , T4
02.08.04.nn	Export active energy -A , T4, Historical values (nn = 00 ... 15)
03.08.00	Total reactive energy R
03.08.00.nn	Total reactive energy R , Historical values (nn = 00 ... 15)
03.08.01	Total reactive energy R , T1
03.08.01.nn	Total reactive energy R , T1, Historical values (nn = 00 ... 15)
03.08.02	Total reactive energy R T2
03.08.02.nn	Total reactive energy R , T2, Historical values (nn = 00 ... 15)
03.08.03	Total reactive energy R , T3
03.08.03.nn	Total reactive energy R , T3, Historical values (nn = 00 ... 15)
03.08.04	Total reactive energy R , T4
03.08.04.nn	Total reactive energy R , T4, Historical values (nn = 00 ... 15)
04.08.00	Export reactive energy -R
04.08.00.nn	Export reactive energy -R , Historical values (nn = 00 ... 15)
04.08.01	Export reactive energy -R , T1
04.08.01.nn	Export reactive energy -R , T1, Historical values (nn = 00 ... 15)
04.08.02	Export reactive energy -R , T2
04.08.02.nn	Export reactive energy -R , T2, Historical values (nn = 00 ... 15)
04.08.03	Export reactive energy -R , T3
04.08.03.nn	Export reactive energy -R , T3, Historical values (nn = 00 ... 15)
04.08.04	Export reactive energy -R , T4
04.08.04.nn	Export reactive energy -R , T4, Historical values (nn = 00 ... 15)
05.08.00	Reactive energy Q1 (Total)
05.08.00.nn	Reactive energy Q1 (Total), Historical values (nn = 00 ... 15)
05.08.01	Reactive energy Q1, T1

OBIS

05.08.01.nn	Reactive energy Q1, T1, Historical values (nn = 00 ... 15)
05.08.02	Reactive energy Q1, T2
05.08.02.nn	Reactive energy Q1, T2, Historical values (nn = 00 ... 15)
05.08.03	Reactive energy Q1, T3
05.08.03.nn	Reactive energy Q1, T3, Historical values (nn = 00 ... 15)
05.08.04	Reactive energy Q1, T4
05.08.04.nn	Reactive energy Q1, T4, Historical values (nn = 00 ... 15)
06.08.00	Reactive energy Q2 (Total)
06.08.00.nn	Reactive energy Q2 (Total), Historical values (nn = 00 ... 15)
06.08.01	Reactive energy Q2, T1
06.08.01.nn	Reactive energy Q2, T1, Historical values (nn = 00 ... 15)
06.08.02	Reactive energy Q2, T2
06.08.02.nn	Reactive energy Q2, T2, Historical values (nn = 00 ... 15)
06.08.03	Reactive energy Q2, T3
06.08.03.nn	Reactive energy Q2, T3, Historical values (nn = 00 ... 15)
06.08.04	Reactive energy Q2, T4
06.08.04.nn	Reactive energy Q2, T4, Historical values (nn = 00 ... 15)
07.08.00	Reactive energy Q3 (Total)
07.08.00.nn	Reactive energy Q3 (Total), Historical values (nn = 00 ... 15)
07.08.01	Reactive energy Q3, T1
07.08.01.nn	Reactive energy Q3, T1, Historical values (nn = 00 ... 15)
07.08.02	Reactive energy Q3, T2
07.08.02.nn	Reactive energy Q3, T2, Historical values (nn = 00 ... 15)
07.08.03	Reactive energy Q3, T3
07.08.03.nn	Reactive energy Q3, T3, Historical values (nn = 00 ... 15)
07.08.04	Reactive energy Q3, T4
07.08.04.nn	Reactive energy Q3, T4, Historical values (nn = 00 ... 15)
08.08.00	Reactive energy Q4 (Total)
08.08.00.nn	Reactive energy Q4 (Total), Historical values (nn = 00 ... 15)
08.08.01	Reactive energy Q4, T1
08.08.01.nn	Reactive energy Q4, T1, Historical values (nn = 00 ... 15)
08.08.02	Reactive energy Q4, T2
08.08.02.nn	Reactive energy Q4, T2, Historical values (nn = 00 ... 15)

OBIS

08.08.03	Reactive energy Q4, T3
08.08.03.nn	Reactive energy Q4, T3, Historical values (nn = 00 ... 15)
08.08.04	Reactive energy Q4, T4
08.08.04.nn	Reactive energy Q4, T4, Historical values (nn = 00 ... 15)
0C.02.00	Configuration change count
0C.02.01	Latest configuration change
0C.02.01.nn	Latest configuration change, Historical values (nn = 00 ... 09)
0C.02.02	Operator ID (latest configuration change)
0C.02.02.nn	Operator ID (latest configuration change) , Historical values (nn = 00 ... 09)
0C.06.00	Date and time of battery replacement
0C.06.01	Battery charge condition (0 = ok , 1 = low)
0C.07.00	Power outage count
0C.52.00	Latest power outage
0C.52.00.nn	Latest power outage, Historical values (nn = 00 ... 20)
0C.54.00	Latest power return
0C.54.00.nn	Latest power return, Historical values (nn = 00 ... 20)
0C.31.92	L1 reverse current count
0C.51.92	L2 reverse current count
0C.71.92	L3 reverse current count
0C.51.08	Latest data readout
0C.54.01	RWP count
0C.54.02	Maximum demand reset count
0C.54.03	Latest maximum demand reset
0C.54.04	Tamper alarm reset count
0C.54.05	Latest tamper alarm reset
0C.54.06	Latest demand threshold violation
0C.54.07	Demand threshold violation count
0C.71.00	Latest terminal cover removal
0C.71.00.nn	Latest terminal cover removal, Historical values (nn = 00 ... 29)
0C.71.01	Latest terminal cover closure
0C.71.01.nn	Latest terminal cover closure, Historical values (nn = 00 ... 29)
0C.71.02	Terminal cover removal / closure count
0C.72.00	Latest meter cover removal

OBIS

0C.72.00.nn	Latest meter cover removal, Historical values (nn = 00 ... 29)
0C.72.01	Latest meter cover closure
0C.72.01.nn	Latest meter cover closure, Historical values (nn = 00 ... 29)
0C.72.02	Terminal meter removal / closure count
0C.81.00	Day profile 1
0C.82.00	Day profile 2
0C.83.00	Day profile 3
0C.84.00	Day profile 4
0F.0F.00	Error register
0C.90.00	Check sum
00.02.00	Firmware version

6. INSTALLATION AND START UP

6.1 Installing the equipment

The meter has been designed in compliance with the DIN 43857 standard, in relation to the size of meters, thus defining the dimensions and fixing points.



Remember that with the unit connected, the terminals may be hazardous to the touch, and opening the covers or removing elements may provide access to parts that are dangerous to the touch. The unit must not be used until it is fully installed.

Warning: All connections must remain inside the terminal cover.

6.2 Meter connection layout

Each MTF301 model has been designed for three-phase networks using three-phase and neutral line asymmetrical connection according to DIN Standard.

The connection layout is engraved inside the terminal cover of the meter.

7. TECHNICAL SERVICE

If you have any questions about the performance or functionality of the meters or any faults, contact our service staff.



Toos Fuse Co.

375 Sanat Blvd.
Toos Industrial Estate
9185113111 Mashhad - Iran

Tel.: +98-511-541 34 23
Fax: +98-511-541 34 26

Email: info@toosfuse.com
Internet: www.toosfuse.com